



Monsieur Marc PIRLOT  
Directeur du Bureau Permanent de la C.I.P.  
Av. de la Renaissance 30  
1000 BRUXELLES

votre communication du

vos références

nos références

date

J4/CD/Circ.1891/JUR.05.11.99/2020

12224

à mentionner dans toute correspondance

25 NOV. 2020

**Objet: Convention pour la reconnaissance réciproque des poinçons d'épreuves des armes à feu portatives, et Règlement avec Annexes I et II, faits à Bruxelles le 1er juillet 1969, dont le Gouvernement belge est dépositaire.**

**Décisions prises par la C.I.P. le 10 novembre 2020.**

Monsieur le Directeur,

J'ai l'honneur de vous faire savoir que je n'ai pas manqué d'informer les Etats intéressés, des décisions prises par la C.I.P. le 10 novembre 2020 en attirant leur attention sur le fait que l'entrée en vigueur de celles-ci aura lieu le 26 mai 2021, si dans l'intervalle aucune opposition ou réserve n'a été formulée.

Ces décisions sont parvenues au Service des Traités (dépositaire de la Convention) le 12 novembre 2020.

**La notification par le Gouvernement belge a été faite pour le 26 novembre 2020, et le délai de 6 mois expirera le 26 mai 2021.**

Veillez agréer, Monsieur le Directeur, l'assurance de ma haute considération.

Pour le Ministre :  
Le Conseiller général,

Ann DE RIDDER



COMMISSION INTERNATIONALE PERMANENTE (C.I.P.)  
POUR L'ÉPREUVE DES ARMES À FEU PORTATIVES

Bureau Permanent  
Av. de la Renaissance, 30  
B-1000 BRUXELLES  
Belgique

---

Au Service Public Fédéral Affaires étrangères,  
Commerce extérieur et Coopération au  
Développement  
Direction des Traités, J4  
EGMONT - Rue des Petits Carmes, 15  
B-1000 Bruxelles

Bruxelles, le 10/11/2020

Objet: Convention pour la reconnaissance réciproque des poinçons d'épreuves des armes à feu portatives, faite à Bruxelles le 1<sup>er</sup> juillet 1969, dont le Gouvernement belge est dépositaire

**Décisions prises par la C.I.P. le 10 novembre 2020**

Madame, Monsieur,

J'ai l'honneur de me référer à la Convention précitée, qui est entrée en vigueur à l'égard des États suivants : Belgique, Allemagne, Autriche, Chili, Émirats Arabes Unis, Espagne, Finlande, France, Royaume-Uni de Grande-Bretagne et d'Irlande du Nord, Hongrie, Italie, Fédération de Russie, République Slovaque, République Tchèque.

En application de la procédure prévue à l'article 7 de son Règlement la Commission Internationale Permanente pour l'épreuve des armes à feu portatives (C.I.P.) a défini les Décisions répertoriées à l'Annexe à la présente lettre. En accord avec le Président de la C.I.P. M. Abdul Rahman AL HAMMADI, la première Décision présentée porte le numéro XXXV-20 puisqu'elle suit les Décisions prises en date du 21 avril 2020.

Conformément aux dispositions de l'article 8 du Règlement de la C.I.P., ces Décisions entrent en vigueur si, dans les six mois qui suivent la notification prévue à l'article 5, paragraphe 2, aucune des Parties contractantes ne s'y oppose ou ne formule des réserves auprès du Gouvernement du Royaume de Belgique.

Par conséquent je vous prie de bien vouloir entamer la procédure de notification et de transmettre ces Décisions aux Parties contractantes.

Voulez-vous m'informer de la situation qui se sera présentée à l'échéance du délai d'opposition ?

Acceptez, Mesdames et Messieurs, l'assurance de mes sentiments très distingués.



Marc Piriot  
Directeur du Bureau Permanent  
de la C.I.P.



**Commission Internationale Permanente**  
**pour l'Épreuve des**  
**Armes à Feu portatives**

La Commission Internationale Permanente pour l'Épreuve des Armes à Feu, se référant à la Convention pour la reconnaissance réciproque des poinçons d'épreuves des armes à feu portatives et au Règlement faits à Bruxelles le 1<sup>er</sup> juillet 1969, a l'honneur de porter à la connaissance des Parties contractantes les Décisions suivantes :

**XXXV-20 à 24 Liste des tableaux TDCC, nouveaux calibres**

*Décisions prises en application du paragraphe 1 de l'article 5 du Règlement.*

**Tableau I**

Calibre 6 mm Advanced Rifle Cartridge	<b>XXXV – 20</b>
Calibre 7-270 Win. Short Mag.	<b>XXXV – 21</b>
Calibre 10X100 BWA	<b>XXXV – 22</b>
Calibre 284 Shehane	<b>XXXV – 23</b>

**Tableau VII**

Calibre 20/58	<b>XXXV – 24</b>
---------------	------------------

## **XXXV-25 à 35 Liste des tableaux TDCC, calibres révisés**

*Décisions prises en application du paragraphe 1 de l'article 5 du Règlement.*

### **Tableau I**

Calibre 300 PRC	<b>XXXV – 25</b>
Calibre 338 Win. Short Mag.	<b>XXXV – 26</b>
Calibre 350 Mag. Rigby	<b>XXXV – 27</b>

### **Tableau II**

Calibre 350 Rigby N°. 2	<b>XXXV – 28</b>
Calibre 400/350 N.E.	<b>XXXV – 29</b>

### **Tableau IV**

Calibre 7,5 FK	<b>XXXV – 30</b>
Calibre 44 Rem. Mag.	<b>XXXV – 31</b>
Calibre 44 Rem. Mag. (carb)	<b>XXXV – 32</b>

### **Tableau X**

Calibre 345 TK	<b>XXXV – 33</b>
Calibre 366 TKM	<b>XXXV – 34</b>
Calibre 40 x 46 BDLR	<b>XXXV – 35</b>

### **Modifications apportées aux calibres :**

- 300 PRC : Dénomination, f cartouche, L3 + G, L3 chambre, G, s
- 338 Win. Short Mag. : G1 cartouche
- 350 Mag. Rigby : Dénomination, b, N, position de la feuillure
- 350 N°2 Rigby: Dénomination, b, N, position de la feuillure
- 400/350 NE : b, N, position de la feuillure
- 7,5 FK : r2 chambre
- 44 Rem. Mag. : Marquage alternatif
- 44 Rem. Mag. (carb) : Marquage alternatif
- 345 TK : G1 chambre, Alpha 1, h, i, F, Z, Q
- 366 TKM : L6 cartouche, L3 + G, G chambre, Alpha 1, h, i, F, Z, Q
- 40 x 46 BDLR X : Feuillure

# Nouveaux calibres

<b>C.I.P.</b>	<b>6 mm Advanced Rifle Cartridge</b> <small>Pays d'origine: US</small>	TAB.	I
		Date	20-11-10
		Révision	
Marquage alternatif: 6 mm ARC			
	<p style="text-align: center;"><b>CARTOUCHE MAXI</b></p> <p><b>Longueurs</b></p> <p>L1 <sup>1)</sup> = 28.47 -0.20            L2 <sup>1)</sup> = 31.90 -0.20            L3 <sup>1)</sup> = 37.85            L4 =            L5 =            L6 = 57.40</p> <p><b>Culot</b></p> <p>R = 1.50            R1 = 11.20            R3 =            E = 3.52            E1 = 9.55            e min = 1.19            δ = 45°            f = 0.38            β = 35°</p> <p><b>Chambre à poudre</b></p> <p>P1 = 11.20            P2 <sup>1)</sup>* = 10.92 -0.20</p> <p><b>Cône de raccordement</b></p> <p>α* = 60°            S* = 37.93            r1 min = 0.76            r2 = 3.18</p> <p><b>Collet</b></p> <p>H1* = 6.96            H2 <sup>1)</sup> = 6.96</p> <p><b>Projectile</b></p> <p>G1 <sup>1)</sup> = 6.18            G2 =            F =            L3+G <sup>1)</sup> = 43.59</p> <p><b>Pressions (Énergies)</b></p> <p><b>Méthode transducteur</b></p> <p>Pmax = 4300 bar            PK = 4945 bar            PE = 5375 bar            M = 17.50            EE = 3000 Joule</p> <p><b>Autres indications</b></p> <p>Fe <sup>1)3)</sup> = 0.10            delta L =</p>	<p style="text-align: center;"><b>CHAMBRE MINI</b></p> <p><b>Longueurs</b></p> <p>L1 = 28.45            L2 = 31.88            L3 <sup>1)</sup> = 38.10</p> <p><b>Cuvette</b></p> <p>R =            R1 = 11.31            R2 =            R3 =            r =</p> <p><b>Chambre à poudre</b></p> <p>E = 3.52            P1 <sup>1)</sup> = 11.26            P2* = 10.95</p> <p><b>Cône de raccordement</b></p> <p>α <sup>1)</sup> = 60°            S* = 37.93            r1 max = 0.76            r2 = 3.18</p> <p><b>Collet</b></p> <p>H1* = 6.99            H2 <sup>1)</sup> = 6.99</p> <p><b>Prise de rayures</b></p> <p>G1 <sup>1)</sup>* = 6.18            G <sup>1)</sup> = 5.74            α1* = 90°            h = 0.41            s = 2.68            i <sup>1)</sup>* = 1°30'            w =</p> <p><b>Canon</b></p> <p>F <sup>1)</sup>* = 6.02            Z <sup>1)</sup> = 6.17</p> <p><b>Rayures</b></p> <p>b = 2.29            N = 6            u = 191.00            Q = 29.52 mm<sup>2</sup></p>	
<p>Échelle 1.28:1</p> <p style="text-align: center;">Dimensions en &lt;&lt; mm &gt;&gt;            Dimensions et tolérances pour les canons            d'épreuve: Voyez Annexe CR 1.</p>	<p>Notes: 1) A' contrôler pour la sécurité            3) Feuillure sur la cone de raccordement            * Dimensions de base</p>		

Reproduction interdite, même partielle, sans l'autorisation de la C.I.P.

<b>C.I.P.</b>	<b>7-270 Win. Short Mag.</b> Pays d'origine: US	TAB. I
		Date 20-11-10
		Révision
Marquage alternatif: 7-270 WSM		
	<b>CARTOUCHE MAXI</b>	<b>CHAMBRE MINI</b>
	<p><b>Longueurs</b></p> <p>L1 <sup>1)</sup> = 42.27 -0.20  L2 <sup>1)</sup> = 46.31 -0.20  L3 <sup>1)</sup> = 53.34  L4 =  L5 =  L6 = 72.64</p> <p><b>Culot</b></p> <p>R = 1.37  R1 = 13.59  R3 =  E = 3.36  E1 = 12.19  e min = 1.02  delta = 45°  f = 0.36  beta = 35°</p> <p><b>Chambre à poudre</b></p> <p>P1 = 14.12  P2 <sup>1)</sup>* = 13.67 -0.20</p> <p><b>Cône de raccordement</b></p> <p>alpha * = 70°  S * = 52.03  r1 min = 1.27  r2 = 2.54</p> <p><b>Collet</b></p> <p>H1 * = 8.01  H2 <sup>1)</sup> = 8.01</p> <p><b>Projectile</b></p> <p>G1 = 7.22  G2 =  F =  L3+G = 57.23</p> <p><b>Pressions (Énergies)</b>  <b>Méthode transducteur</b></p> <p>Pmax = 4400 bar  PK = 5060 bar  PE = 5500 bar  M = 25.00  EE = 4725 Joule</p> <p><b>Autres indications</b></p> <p>Fe <sup>1)3)</sup> = 0.10  delta L = 0.11</p>	<p><b>Longueurs</b></p> <p>L1 = 42.14  L2 = 46.12  L3 <sup>1)</sup> = 53.59</p> <p><b>Cuvette</b></p> <p>R =  R1 = 14.19  R2 =  R3 =  r =</p> <p><b>Chambre à poudre</b></p> <p>E = 3.36  P1 <sup>1)</sup> = 14.15  P2 * = 13.70</p> <p><b>Cône de raccordement</b></p> <p>alpha <sup>1)</sup>* = 70°  S * = 51.93  r1 max = 1.27  r2 = 3.05</p> <p><b>Collet</b></p> <p>H1 * = 8.13  H2 <sup>1)</sup> = 8.13</p> <p><b>Prise de rayures</b></p> <p>G1 <sup>1)</sup>* = 7.23  G <sup>1)</sup> = 3.89  alpha 1 = 90°  h * = 0.45  s =  i <sup>1)</sup>* = 1°30'  w =</p> <p><b>Canon</b></p> <p>F <sup>1)</sup>* = 7.05  Z <sup>1)</sup> = 7.21</p> <p><b>Rayures</b></p> <p>b = 4.06  N = 4  u = 215.90  Q = 40.42 mm<sup>2</sup></p>
Échelle 1.03:1		
Dimensions en << mm >> Dimensions et tolérances pour les canons d'épreuve: Voyez Annexe CR1.		Notes: 1) A' contrôler pour la sécurité 3) Feuillure sur la cone de raccordement * Dimensions de base

Reproduction interdite, même partielle, sans l'autorisation de la C.I.P.

C.I.P.	10x100 BWA Pays d'origine: IT	TAB.	I
		Date	20-11-10
		Révision	
	<p style="text-align: center;"><b>CARTOUCHE MAXI</b></p> <p><b>Longueurs</b></p> L1 <sup>1)</sup> = 79.35 -0.20 L2 <sup>1)</sup> = 84.74 -0.20 L3 <sup>1)</sup> = 100.00 L4 = L5 = L6 = 138.40 <p><b>Culot</b></p> R = 2.20 R1 = 20.35 R3 = E = 6.27 E1 = 17.20 e min = 1.90 delta = 36° f = 0.84 beta = 45° <p><b>Chambre à poudre</b></p> P1 = 20.35 P2 <sup>1)</sup> * = 19.57 -0.20 <p><b>Cône de raccordement</b></p> alpha * = 60° S * = 96.31 r1 min = 4.50 r2 = 3.00 <p><b>Collet</b></p> H1 * = 13.35 H2 <sup>1)</sup> = 13.35 <p><b>Projectile</b></p> G1 <sup>1)</sup> = 10.32 G2 = F = L3+G <sup>1)</sup> = 106.89 <p><b>Pressions (Énergies)</b></p> <p><b>Méthode transducteur</b></p> Pmax = 3700 bar PK = 4255 bar PE = 4625 bar M = 25.00 EE = 15000 Joule <p><b>Autres indications</b></p> Fe <sup>1)3)</sup> = 0.15 delta L =	<p style="text-align: center;"><b>CHAMBRE MINI</b></p> <p><b>Longueurs</b></p> L1 = 79.36 L2 = 84.75 L3 <sup>1)</sup> = 100.20 <p><b>Cuvette</b></p> R = R1 = 20.45 R2 = R3 = r = <p><b>Chambre à poudre</b></p> E = 6.27 P1 <sup>1)</sup> = 20.43 P2 * = 19.67 <p><b>Cône de raccordement</b></p> alpha <sup>1)</sup> * = 60° S * = 96.40 r1 max = 4.50 r2 = 3.00 <p><b>Collet</b></p> H1 * = 13.45 H2 <sup>1)</sup> = 13.45 <p><b>Prise de rayures</b></p> G1 <sup>1)</sup> * = 10.37 G = 6.89 alpha 1 = 145° h = 0.48 s * = 2.88 i <sup>1)</sup> * = 1°30' w = <p><b>Canon</b></p> F <sup>1)</sup> * = 10.16 Z <sup>1)</sup> = 10.36 <p><b>Rayures</b></p> b = 2.57 N = 8 u = 330.20 Q = 83.15 mm <sup>2</sup>	
			<p>Échelle 1:1.7</p> <p style="text-align: center;">Dimensions en &lt;&lt; mm &gt;&gt; Dimensions et tolérances pour les canons d'épreuve: Voyez Annexe CR1.</p>

Reproduction interdite, même partielle, sans l'autorisation de la C.I.P.

C.I.P.	284 Shehane Pays d'origine: US	TAB.	I
		Date	20-11-10
		Révision	
	<p><b>CARTOUCHE MAXI</b></p> <p><b>Longueurs</b></p> L1 <sup>1)</sup> = 44.77 -0.20 L2 <sup>1)</sup> = 47.90 -0.20 L3 <sup>1)</sup> = 54.87 L4 = L5 = L6 = 78.00 <p><b>Culot</b></p> R = 1.37 R1 = 12.01 R3 = E = 3.76 E1 = 10.39 e min = 1.02 delta = 40° f = 0.38 beta = 35° <p><b>Chambre à poudre</b></p> P1 = 12.69 P2 <sup>1)</sup> * = 12.29 -0.20 <p><b>Cône de raccordement</b></p> alpha * = 70° S * = 53.54 r1 min = 0.76 r2 = 3.18 <p><b>Collet</b></p> H1 * = 7.90 H2 <sup>1)</sup> = 7.90 <p><b>Projectile</b></p> G1 <sup>1)</sup> = 7.21 G2 = F = L3+G <sup>1)</sup> = 64.39 <p><b>Pressions (Énergies)</b></p> <p><b>Méthode transducteur</b></p> Pmax = 4400 bar PK = 5060 bar PE = 5500 bar M = 25.00 EE = 4300 Joule <p><b>Autres indications</b></p> Fe <sup>1)3)</sup> = 0.10 delta L =	<p><b>CHAMBRE MINI</b></p> <p><b>Longueurs</b></p> L1 = 44.78 L2 = 47.90 L3 <sup>1)</sup> = 54.99 <p><b>Cuvette</b></p> R = R1 = 12.77 R2 = R3 = r = <p><b>Chambre à poudre</b></p> E = 3.76 P1 <sup>1)</sup> = 12.73 P2 * = 12.32 <p><b>Cône de raccordement</b></p> alpha <sup>1)</sup> * = 70° S * = 53.58 r1 max = 0.76 r2 = 3.18 <p><b>Collet</b></p> H1 * = 7.95 H2 <sup>1)</sup> = 7.95 <p><b>Prise de rayures</b></p> G1 <sup>1)</sup> * = 7.23 G <sup>1)</sup> = 9.52 alpha 1 * = 90° h = 0.36 s = 5.70 i <sup>1)</sup> * = 1°30' w = <p><b>Canon</b></p> F <sup>1)</sup> * = 7.03 Z <sup>1)</sup> = 7.21 <p><b>Rayures</b></p> b = 2.79 N = 4 u = 228.00 Q = 39.85 mm <sup>2</sup>	
<p>Échelle 1.04:1</p> <p>Dimensions en &lt;&lt; mm &gt;&gt;  Dimensions et tolérances pour les canons  d'épreuve: Voyez Annexe CR1.</p>	<p>Notes: 1) A' contrôler pour la sécurité  3) Feuillure sur la cone de raccordement  * Dimensions de base</p>		

Reproduction interdite, même partielle, sans l'autorisation de la C.I.P.

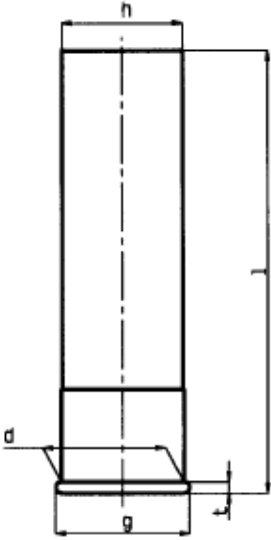
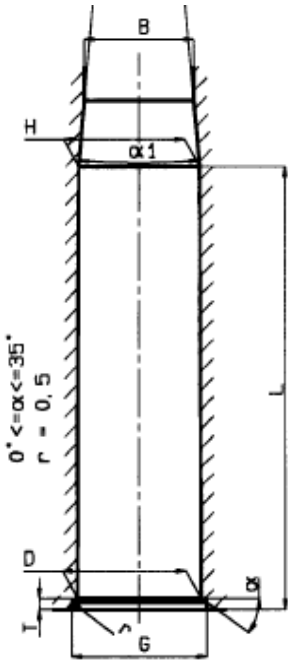
C.I.P.	Cal. 20	TAB.	VII		
		Date	84-06-14		
		Révision	20-11-10		
		<b>CARTOUCHE MAXIMALE</b>			
		<p>Dimens. Valeur Tolér.</p> <p>d<sup>1)</sup> = 17.70 - 0.22  g = 19.40 - 0.40  t<sup>1)</sup> = 1.55 - 0.35      Marquage  h = 17.35 - 0.49  l = 58.00 - 2.50      20/58  l = 65.00 - 2.50      20/65  l = 67.50 - 2.50      20/67  l = 69.80 - 2.50      20/70  l = 76.00 - 2.50      20/76  l = 88,70 - 2,50      20/89</p>			
		<b>CHAMBRE MINIMALE</b>			
		<p>Dimens. Valeur Tolér.</p> <p>D<sup>1)</sup> = 17.75 + 0.10  G = 19.50 + 0.10  T<sup>1)</sup> = 1.55 + 0.10  H<sup>1)</sup> = 17.40 + 0.10      Marquage      Pression transducteur  B<sup>1)</sup> = 15.70 + 0.50      Pmax      PK      PE      M  alpha 1<sup>1)</sup> = 10°30' max      bar  L<sup>1)</sup> = 58.10 + 2.00      20/58      830      950      1040      25/30  L<sup>1)</sup> = 65.10 + 2.00      20/65      830      950      1040      25/30  L<sup>1)</sup> = 67.60 + 2.00      20/67      830      950      1040      25/30  L<sup>1)</sup> = 69.90 + 2.00      20/70      830      950      1040      25/30  L<sup>1)</sup> = 76.20 + 2.00      20/76      1050      1200      1320      25/30  L<sup>1)</sup> = 88,90 + 2,00      20/89      1050      1200      1320      25/30</p> <p>Feuillure de l'arme</p> <p>Fe = 0.10      manomètre  Fe<sup>1)</sup> = 0.20      à bascule  Fe<sup>1)</sup> = 0.35      automatique</p>			
Echelle 1:1					
Dimensions en « mm » Dimensions et tolérances pour les canons d'épreuve : <span style="border: 1px solid black; padding: 2px;">Annexe CR4</span>		Notes : 1) A contrôler pour la sécurité			

# Calibres révisés

<b>C.I.P.</b>	<b>300 Precision Rifle Cartridge</b> <small>Pays d'origine: US</small>	TAB.	I
		Date	19-05-22
		Révision	20-11-10
Marquage alternatif: 300 PRC			
	<p><b>CARTOUCHE MAXI</b></p> <p><b>Longueurs</b></p> <p>L1 <sup>1)</sup> = 53.89 -0.20            L2 <sup>1)</sup> = 57.72 -0.20            L3 <sup>1)</sup> = 65.53            L4 =            L5 =            L6 = 93.98</p> <p><b>Culot</b></p> <p>R = 1.27            R1 = 13.51            R3 =            E = 3.25            E1 = 12.07            e min = 0.94            delta = 35°            f = 0.41            beta = 35°</p> <p><b>Chambre à poudre</b></p> <p>P1 = 13.53            P2 <sup>1)</sup>* = 13.08 -0.20</p> <p><b>Cône de raccordement</b></p> <p>alpha <sup>1)</sup>* = 60°            S* = 65.22            r1 min = 0.76            r2 = 3.18</p> <p><b>Collet</b></p> <p>H1 <sup>*</sup> = 8.66            H2 <sup>1)</sup> = 8.66</p> <p><b>Projectile</b></p> <p>G1 <sup>1)</sup> = 7.83            G2 =            F =            L3+G <sup>1)</sup> = 76.07</p> <p><b>Pressions (Énergies)</b>  <b>Méthode transducteur</b></p> <p>Pmax = 4400 bar            PK = 5060 bar            PE = 5500 bar            M = 25.00            EE = 5800 Joule</p> <p><b>Autres indications</b></p> <p>Fe <sup>1)3)</sup> = 0.10            delta L = 0.11</p>	<p><b>CHAMBRE MINI</b></p> <p><b>Longueurs</b></p> <p>L1 = 53.76            L2 = 57.57            L3 <sup>1)</sup> = 65.72</p> <p><b>Cuvette</b></p> <p>R =            R1 = 13.58            R2 =            R3 =            r =</p> <p><b>Chambre à poudre</b></p> <p>E = 3.25            P1 <sup>1)</sup> = 13.55            P2 <sup>*</sup> = 13.11</p> <p><b>Cône de raccordement</b></p> <p>alpha <sup>1)</sup>* = 60°            S* = 65.11            r1 max = 0.76            r2 = 3.18</p> <p><b>Collet</b></p> <p>H1 <sup>*</sup> = 8.71            H2 <sup>1)</sup> = 8.69</p> <p><b>Prise de rayures</b></p> <p>G1 <sup>1)</sup>* = 7.84            G = 10.54            alpha1 = 90°            h = 0.43            s <sup>*</sup> = 6.34            i <sup>1)</sup>* = 1°30'            w =</p> <p><b>Canon</b></p> <p>F <sup>1)</sup>* = 7.62            Z <sup>1)</sup> = 7.82</p> <p><b>Rayures</b></p> <p>b = 2.92            N = 6            u = 216.00            Q = 47.40 mm<sup>2</sup></p>	
<p>Échelle 1:1.16</p> <p style="text-align: center;">Dimensions en &lt;&lt; mm &gt;&gt;            Dimensions et tolérances pour les canons            d'épreuve: Voyez Annexe CR 1.</p>	<p>Notes: 1) A* contrôler pour la sécurité            3) Feuillure sur la cone de raccordement            * Dimensions de base</p>		

Reproduction interdite, même partielle, sans l'autorisation de la C.I.P.

C.I.P.	338 Win. Short Mag. Pays d'origine: US	TAB.	I
		Date	02-01-22
		Révision	20-11-10
	<p align="center"><b>CARTOUCHE MAXI</b></p> <p><b>Longueurs</b></p> L1 <sup>1)</sup> = 38.64 -0.20 L2 <sup>1)</sup> = 41.74 -0.20 L3 <sup>1)</sup> = 49.78 L4 = L5 = L6 = 69.78 <b>Culot</b> R = 1.37 R1 = 13.59 R3 = E = 3.35 E1 = 12.19 e min = 1.02 delta = 45° f = 0.36 beta = 35° <b>Chambre à poudre</b> P1 = 14.12 P2 <sup>1)</sup> * = 13.71 -0.20 <b>Cône de raccordement</b> alpha * = 70° S * = 48.43 r1 min = 1.27 r2 = 2.54 <b>Collet</b> H1 * = 9.37 H2 <sup>1)</sup> = 9.37 <b>Projectile</b> G1 <sup>1)</sup> = 8.61 G2 = F = L3+G <sup>1)</sup> = 57.39 <b>Pressions (Énergies)</b> <b>Méthode transducteur</b> Pmax = 4150 bar PK = 4773 bar PE = 5188 bar M = 25.00 EE = 4935 Joule <b>Autres indications</b> Fe <sup>1)</sup> = 0.10 delta L = 0.10	<p align="center"><b>CHAMBRE MINI</b></p> <p><b>Longueurs</b></p> L1 = 38.51 L2 = 41.60 L3 <sup>1)</sup> = 50.04 <b>Cuvette</b> R = R1 = 14.19 R2 = R3 = r = <b>Chambre à poudre</b> E = 3.35 P1 <sup>1)</sup> = 14.15 P2 * = 13.75 <b>Cône de raccordement</b> alpha <sup>1)</sup> * = 70° S * = 48.33 r1 max = 1.27 r2 = 3.05 <b>Collet</b> H1 * = 9.42 H2 <sup>1)</sup> = 9.40 <b>Prise de rayures</b> G1 <sup>1)</sup> * = 8.71 G <sup>1)</sup> = 7.61 alpha 1 * = 90° h = 0.34 s = 2.89 i <sup>1)</sup> * = 2° w = <b>Canon</b> F <sup>1)</sup> * = 8.38 Z <sup>1)</sup> = 8.59 <b>Rayures</b> b = 2.79 N = 6 u = 254.00 Q = 56.95 mm <sup>2</sup>	
<p>Échelle 1.03:1</p> <p align="center">Dimensions en &lt;&lt; mm &gt;&gt; Dimensions et tolérances pour les canons d'épreuve: Voyez Annexe CR 1.</p>	<p>Notes: 1) A' contrôler pour la sécurité * Dimensions de base</p>		

Reproduction interdite, même partielle, sans l'autorisation de la C.I.P.

<b>C.I.P.</b>	<b>350 Rigby Mag.</b> Pays d'origine: GB	TAB. I
		Date 84-06-14
		Révision 20-11-10
Marquage alternatif: 350 Mag. Rigby		
	<b>CARTOUCHE MAXI</b>	<b>CHAMBRE MINI</b>
	<p><b>Longueurs</b></p> <p>L1 <sup>1)</sup>* = 57.15 -0.20  L2 <sup>1)</sup>* = 57.99 -0.20  L3 <sup>1)</sup> = 69.85  L4 =  L5 =  L6 = 90.80</p> <p><b>Culot</b></p> <p>R = 1.52  R1 = 13.36  R3 =  E = 3.81  E1 = 11.61  e min = 0.76  δ = 26°51'36"  f =  β =</p> <p><b>Chambre à poudre</b></p> <p>P1 = 13.16  P2 <sup>1)</sup>* = 11.43 -0.20</p> <p><b>Cône de raccordement</b></p> <p>α = 90°  S = 62.87  r1 min =  r2 =</p> <p><b>Collet</b></p> <p>H1 * = 9.75  H2 <sup>1)</sup> = 9.73</p> <p><b>Projectile</b></p> <p>G1 <sup>1)</sup> = 9.07  G2 =  F =  L3+G <sup>1)</sup> = 74.74</p> <p><b>Pressions (Énergies)</b></p> <p><b>Méthode transducteur</b></p> <p>Pmax = 3100 bar  PK = 3565 bar  PE = 3875 bar  M = 25.00  EE = 4810 Joule</p> <p><b>Autres indications</b></p> <p>Fe <sup>1)3)</sup> = 0.15  delta L = 0.04</p>	<p><b>Longueurs</b></p> <p>L1 * = 57.10  L2 * = 57.94  L3 <sup>1)</sup> = 70.15</p> <p><b>Cuvette</b></p> <p>R = 1.52  R1 = 13.41  R2 =  R3 =  r =</p> <p><b>Chambre à poudre</b></p> <p>E = 3.81  P1 <sup>1)</sup> = 13.18  P2 * = 11.46</p> <p><b>Cône de raccordement</b></p> <p>α <sup>1)</sup> = 90°  S = 62.83  r1 max =  r2 =</p> <p><b>Collet</b></p> <p>H1 * = 9.78  H2 <sup>1)</sup> = 9.75</p> <p><b>Prise de rayures</b></p> <p>G1 <sup>1)</sup>* = 9.13  G <sup>1)</sup>* = 4.89  α1 = 90°  h * = 0.31  s =  i <sup>1)</sup>* = 1°30'  w =</p> <p><b>Canon</b></p> <p>F <sup>1)</sup>* = 8.89  Z <sup>1)</sup> = 9.06</p> <p><b>Rayures</b></p> <p>b = 2.79  N = 6  u = 305.00  Q = 63.52 mm<sup>2</sup></p>
<p>Échelle 1:1.12</p> <p style="text-align: center;">Dimensions en &lt;&lt; mm &gt;&gt;  Dimensions et tolérances pour les canons  d'épreuve: Voyez Annexe CR 1.</p>	<p>Notes: 1) A' contrôler pour la sécurité  3) Feuillure sur la cone de raccordement  * Dimensions de base</p>	

Reproduction interdite, même partielle, sans l'autorisation de la C.I.P.

<b>C.I.P.</b>	<b>350 Rigby No. 2</b> Pays d'origine: GB	TAB. <span style="float: right;">II</span>
		Date <span style="float: right;">84-06-14</span>
		Révision <span style="float: right;">20-11-10</span>
Marquage alternatif: 350 No. 2 Rigby		
	<p><b>CARTOUCHE MAXI</b></p> <p><b>Longueurs</b></p> <p>L1 * = 53.34 L2 * = 57.15 L3 1) = 69.88 L4 = L5 = L6 = 93.73</p> <p><b>Culot</b></p> <p>R 1) = 1.27 R1 = 13.46 R3 = E = E1 = e min = delta = f = beta =</p> <p><b>Chambre à poudre</b></p> <p>P1 = 11.96 P2 * = 10.64</p> <p><b>Cône de raccordement</b></p> <p>alpha = 13°37'13" S = 97.89 r1 min = 8.13 r2 = 8.13</p> <p><b>Collet</b></p> <p>H1 * = 9.73 H2 1) = 9.70</p> <p><b>Projectile</b></p> <p>G1 1) = 9.04 G2 = F = L3+G 1) = 80.51</p> <p><b>Pressions (Énergies)</b></p> <p><b>Méthode transducteur</b></p> <p>Pmax = 3300 bar PK = 3795 bar PE = 4125 bar M = 25.00 EE = 4900 Joule</p> <p><b>Autres indications</b></p> <p>Fe 1)4) = 0.15 delta L =</p>	<p><b>CHAMBRE MINI</b></p> <p><b>Longueurs</b></p> <p>L1 * = 53.37 L2 * = 57.18 L3 1) = 70.13</p> <p><b>Cuvette</b></p> <p>R 1) = 1.30 R1 = 13.72 R2 = R3 = r =</p> <p><b>Chambre à poudre</b></p> <p>E = P1 1) = 11.99 P2 * = 10.67</p> <p><b>Cône de raccordement</b></p> <p>alpha = 13°46'06" S = 97.56 r1 max = 8.13 r2 = 8.13</p> <p><b>Collet</b></p> <p>H1 * = 9.75 H2 1) = 9.73</p> <p><b>Prise de rayures</b></p> <p>G1 1)* = 9.10 G 1)* = 10.63 alpha1 = 90° h * = 0.32 s = i 1) = 1°15' w =</p> <p><b>Canon</b></p> <p>F 1)* = 8.65 Z 1) = 9.00</p> <p><b>Rayures</b></p> <p>b = 3.08 N = 6 u = 304.00 Q = 62.07 mm<sup>2</sup></p>
<p>Échelle 1:1.16</p> <p style="text-align: center;">Dimensions en &lt;&lt; mm &gt;&gt; Dimensions et tolérances pour les canons d'épreuve: Voyez Annexe CR 1.</p>	<p>Notes: 1) A* contrôler pour la sécurité 4) Feuillure sur la bourrelet * Dimensions de base</p>	

Reproduction interdite, même partielle, sans l'autorisation de la C.I.P.

C.I.P.	400/350 N.E. Pays d'origine: GB	TAB.	II
		Date	84-06-14
		Révision	20-11-10
	<b>CARTOUCHE MAXI</b>		<b>CHAMBRE MINI</b>
	<b>Longueurs</b> L1 * = 53.34 L2 * = 57.15 L3 1) = 69.85 L4 = L5 = L6 = 93.73  <b>Culot</b> R 1) = 1.27 -0.25 R1 = 13.46 R3 = E = E1 = e min = delta = f = beta =  <b>Chambre à poudre</b> P1 = 11.96 P2 * = 10.64  <b>Cône de raccordement</b> alpha = 13°37'13" S = 97.89 r1 min = 8.13 r2 = 8.13  <b>Collet</b> H1 * = 9.73 H2 1) = 9.70  <b>Projectile</b> G1 1) = 9.04 G2 = F = L3+G 1) = 80.48  <b>Pressions (Énergies)</b> <b>Méthode transducteur</b> Pmax = 2800 bar PK = 3220 bar PE = 3500 bar M = 25.00 EE = 4292 Joule  <b>Autres indications</b> Fe 1)4) = 0.15 delta L =	<b>Longueurs</b> L1 * = 53.37 L2 * = 57.18 L3 1) = 70.10  <b>Cuvette</b> R 1) = 1.30 R1 = 13.72 R2 = R3 = r =  <b>Chambre à poudre</b> E = P1 1) = 11.99 P2 * = 10.67  <b>Cône de raccordement</b> alpha = 13°46'06" S = 97.56 r1 max = 8.13 r2 = 8.13  <b>Collet</b> H1 * = 9.75 H2 1) = 9.73  <b>Prise de rayures</b> G1 1)* = 9.10 G 1)* = 10.63 alpha l = 90° h * = 0.32 s = i 1) = 1°15' w =  <b>Canon</b> F 1)* = 8.65 Z 1) = 9.00  <b>Rayures</b> b = 3.08 N = 6 u = 406.00 Q = 62.07 mm <sup>2</sup>	
Échelle 1:1.13  Dimensions en << mm >> Dimensions et tolérances pour les canons d'épreuve: Voyez Annexe CR 1.		Notes: 1) A' contrôler pour la sécurité 4) Feuillure sur la bourrelet * Dimensions de base	

Reproduction interdite, même partielle, sans l'autorisation de la C.I.P.

C.I.P.	7,5 FK Pays d'origine: CZ	TAB.	IV
		Date	15-05-19
		Révision	20-11-10
	<b>CARTOUCHE MAXI</b>		<b>CHAMBRE MINI</b>
	<b>Longueurs</b> L1 <sup>1)</sup> = 21.01 -0.20 L2 <sup>1)</sup> = 23.00 -0.20 L3 <sup>1)</sup> = 27.00 L4 = L5 = L6 = 35.00  <b>Culot</b> R = 1.40 R1 = 10.80 R3 = E = 3.65 E1 = 8.60 e min = 1.15 delta = 45° f = 0.50 beta = 45°  <b>Chambre à poudre</b> P1 = 10.80 P2 <sup>1)*</sup> = 10.75 -0.15  <b>Cône de raccordement</b> alpha * = 60° S * = 30.31 r1 min = 0.50 r2 = 2.00  <b>Collet</b> H1 * = 8.45 H2 <sup>1)</sup> = 8.45  <b>Projectile</b> G1 <sup>1)</sup> = 7.80 G2 = F = L3+G <sup>1)</sup> = 33.57  <b>Pressions (Énergies)</b> <b>Méthode transducteur</b> Pmax = 3500 bar PK = 4025 bar PE = 4550 bar M = 17.50  <b>Autres indications</b> Fe <sup>1)3)</sup> = 0.20 delta L = 0.02		<b>Longueurs</b> L1 = 20.98 L2 = 22.92 L3 <sup>1)</sup> = 27.20  <b>Cuvette</b> R = R1 = 10.90 R2 = R3 = r =  <b>Chambre à poudre</b> E = 3.30 P1 <sup>1)</sup> = 10.90 P2 * = 10.80  <b>Cône de raccordement</b> alpha <sup>1)*</sup> = 60° S * = 30.33 r1 max = 0.50 r2 = 1.30  <b>Collet</b> H1 * = 8.56 H2 <sup>1)</sup> = 8.53  <b>Prise de rayures</b> G1 <sup>1)*</sup> = 7.85 G <sup>1)</sup> = 6.57 alpha l = 90° h = 0.34 s * = 3.40 i <sup>1)*</sup> = 3°04'11" w =  <b>Canon</b> F <sup>1)*</sup> = 7.51 Z <sup>1)</sup> = 7.77  <b>Rayures</b> b = 3.75 N = 4 u = 270.00 Q = 46.33 mm <sup>2</sup>
Échelle 1.33:1			
Dimensions en << mm >> Dimensions et tolérances pour les canons d'épreuve: Voyez Annexe CR1.		Notes: 1) A' contrôler pour la sécurité 3) Feuillure sur la cone de raccordement * Dimensions de base	

Reproduction interdite, même partielle, sans l'autorisation de la C.I.P.

C.I.P.	345 TK Pays d'origine: RU	TAB.	X
		Date	19-05-22
		Révision	20-11-10
	<p align="center"><b>CARTOUCHE MAXI</b></p> <p><b>Longueurs</b></p> L1 = L2 = L3 <sup>1)</sup> = 22.00 -0.25 L4 = L5 = L6 = 30.00 <p><b>Culot</b></p> R = 1.50 R1 = 10.00 R3 = E = 3.20 E1 = 8.60 e min = 1.00 $\delta$ = 45° f = 0.50 $\beta$ = 45° <p><b>Chambre à poudre</b></p> P1 = 10.00 P2 = <p><b>Cône de raccordement</b></p> $\alpha$ = S = r1 min = r2 = <p><b>Collet</b></p> H1 = H2 <sup>1)</sup> = 9.67 <p><b>Projectile</b></p> G1 <sup>1)</sup> * = 9.00 G2 = F = L3+G <sup>1)</sup> = 27.80 <p><b>Pressions (Énergies)</b>  <b>Méthode transducteur</b></p> Pmax = 2800 bar PK = 3220 bar PE = 3640 bar M = 12.50 <p><b>Autres indications</b></p> Fe <sup>6)</sup> = 0.30 delta L =	<p align="center"><b>CHAMBRE MINI</b></p> <p><b>Longueurs</b></p> L1 = L2 = L3 <sup>1)</sup> = 22.00 <p><b>Cuvette</b></p> R = R1 = 10.08 R2 = R3 = r = <p><b>Chambre à poudre</b></p> E = 3.30 P1 <sup>1)</sup> = 10.05 P2 = <p><b>Cône de raccordement</b></p> $\alpha$ = S = r1 max = r2 = <p><b>Collet</b></p> H1 = H2 <sup>1)</sup> = 9.69 <p><b>Prise de rayures</b></p> G1 <sup>1)</sup> * = 8.95 G <sup>1)</sup> = 5.80 $\alpha$ 1 = 150° h = 0.10 s* = 1.45 i <sup>1)</sup> * = 1°07'10" w = <p><b>Canon</b></p> F <sup>1)</sup> * = 8.78 Z <sup>1)</sup> = 8.78 <p><b>Rayures</b></p> b = N = u = Q = 60.55 mm <sup>2</sup>	
			<p>Échelle 1.7:1</p> <p align="center">Dimensions en &lt;&lt; mm &gt;&gt;  Dimensions et tolérances pour les canons  d'épreuve: Voyez Annexe CR1.</p>

Reproduction interdite, même partielle, sans l'autorisation de la C.I.P.

C.I.P.	44 Rem. Mag. Pays d'origine: US	TAB.	IV	
		Date	86-12-14	
		Révision	20-11-10	
Marquage alternatif: 44 Magnum - 44 Mag.				
	<b>CARTOUCHE MAXI</b> <b>Longueurs</b> L1 = L2 = L3 <sup>1)</sup> = 32.64 L4 = L5 = L6 = 40.89 <b>Culot</b> R <sup>1)</sup> = 1.52 -0.25 R1 = 13.06 R3 = E = E1 = e min = δ = f = 0.40 β = 35° <b>Chambre à poudre</b> P1 = 11.61 P2 = <b>Cône de raccordement</b> α = S = r1 min = r2 = <b>Collet</b> H1 = H2 <sup>1)</sup> = 11.58 <b>Projectile</b> G1 <sup>1)</sup> = 10.97 G2 = F = L3+G <sup>1)</sup> = 46.44 <b>Pressions (Énergies)</b> <b>Méthode transducteur</b> Pmax = 2800 bar PK = 3220 bar PE = 3640 bar M = 17.50 <b>Autres indications</b> Fe <sup>1)</sup> = 0.25 delta L =		<b>CHAMBRE MINI</b> <b>Longueurs</b> L1 = L2 = L3 <sup>1)</sup> = 33.23 <b>Cuvette</b> R <sup>1)</sup> = 1.52 R1 = 13.18 R2 = R3 = r = <b>Chambre à poudre</b> E = P1 <sup>1)</sup> = 11.66 P2 = <b>Cône de raccordement</b> α = S = r1 max = r2 = <b>Collet</b> H1 = H2 <sup>1)</sup> = 11.63 <b>Prise de rayures</b> G1 <sup>1)</sup> * = 10.99 G <sup>1)</sup> = 13.80 α1 * = 22°12' h = 1.63 s = 11.51 i <sup>1)</sup> * = 5° w = <b>Canon</b> F <sup>1)</sup> * = 10.59 Z <sup>1)</sup> = 10.90 <b>Rayures</b> b = 2.73 N = 6 u = 508.00 Q = 90.65 mm <sup>2</sup>	
		Notes: 1) A' contrôler pour la sécurité * Dimensions de base		
Échelle 1.22:1 Dimensions en << mm >> Dimensions et tolérances pour les canons d'épreuve: Voyez Annexe CR 1.				

Reproduction interdite, même partielle, sans l'autorisation de la C.I.P.

<b>C.I.P.</b>	<b>44 Rem. Mag. (carb)</b> Pays d'origine: US	TAB. <b>IV</b>
		Date <b>86-12-14</b>
		Révision <b>20-11-10</b>
Marquage alternatif: 44 Magnum - 44 Mag.		
	<b>CARTOUCHE MAXI</b> <b>Longueurs</b> L1 = L2 = L3 = L4 = L5 = L6 = <b>Culot</b> R = R1 = R3 = E = E1 = e min = delta = f = beta = <b>Chambre à poudre</b> P1 = P2 = <b>Cône de raccordement</b> alpha = S = r1 min = r2 = <b>Collet</b> H1 = H2 = <b>Projectile</b> G1 = G2 = F = L3+G = <b>Pressions (Énergies)</b>  <b>Autres indications</b> Fe <sup>1)</sup> = 0.15 delta L =	<b>CHAMBRE MINI</b> <b>Longueurs</b> L1 = L2 = L3 <sup>1)</sup> = 33.23 <b>Cuvette</b> R <sup>1)</sup> = 1.52 R1 = 13.18 R2 = R3 = r = <b>Chambre à poudre</b> E = P1 <sup>1)</sup> = 11.66 P2 = <b>Cône de raccordement</b> alpha = S = r1 max = r2 = <b>Collet</b> H1 = H2 <sup>1)</sup> = 11.63 <b>Prise de rayures</b> G1 <sup>1)</sup> * = 11.63 G <sup>1)</sup> = 2.65 alpha 1 * = h = s = i <sup>1)</sup> * = 11°06' w = <b>Canon</b> F <sup>1)</sup> * = 10.59 Z <sup>1)</sup> = 10.90 <b>Rayures</b> b = 2.73 N = 6 u = 508.00 Q = 90.65 mm <sup>2</sup>
	Échelle 1.41:1  Dimensions en << mm >> Dimensions et tolérances pour les canons d'épreuve: Voyez Annexe .	Notes: 1) A <sup>1)</sup> contrôler pour la sécurité * Dimensions de base

Reproduction interdite, même partielle, sans l'autorisation de la C.I.P.

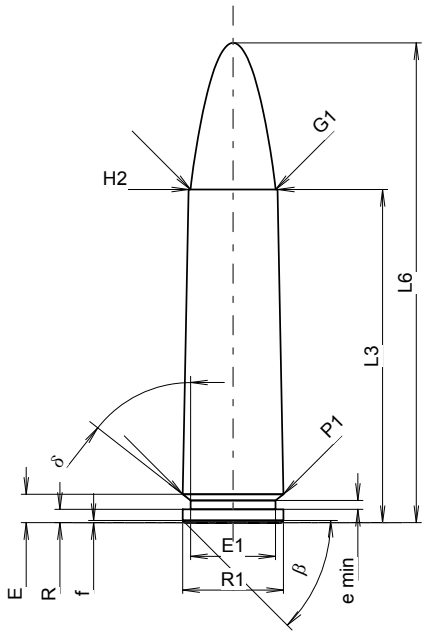
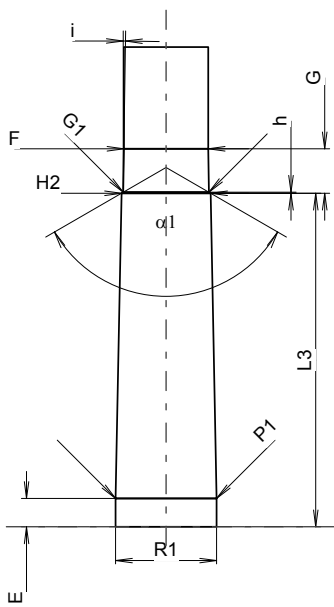
C.I.P.	366 TKM Pays d'origine: RU	TAB.	X
		Date	16-05-18
		Révision	20-11-10
	<b>CARTOUCHE MAXI</b>		<b>CHAMBRE MINI</b>
	<b>Longueurs</b> L1 = L2 = L3 <sup>1)</sup> = 37.50 -0.25 L4 = L5 = L6 = 54.00  <b>Culot</b> R = 1.50 R1 = 11.35 R3 = E = 3.20 E1 = 9.56 e min = 1.00 $\delta$ = 51°58'12" f = 0.25 $\beta$ = 45°  <b>Chambre à poudre</b> P1 = 11.35 P2 =  <b>Cône de raccordement</b> $\alpha$ = S = r1 min = r2 =  <b>Collet</b> H1 = H2 <sup>1)</sup> = 10.00  <b>Projectile</b> G1 <sup>1)</sup> = 9.58 G2 = F = L3+G <sup>1)</sup> = 42.50  <b>Pressions (Énergies)</b> <b>Méthode transducteur</b> Pmax = 3300 bar PK = 3795 bar PE = 4290 bar M = 25.00  <b>Autres indications</b> Fe <sup>1)6)</sup> = 0.15 delta L =		<b>Longueurs</b> L1 = L2 = L3 <sup>1)</sup> = 37.55  <b>Cuvette</b> R = R1 = 11.38 R2 = R3 = r =  <b>Chambre à poudre</b> E = 3.20 P1 <sup>1)</sup> = 11.37 P2 =  <b>Cône de raccordement</b> $\alpha$ = S = r1 max = r2 =  <b>Collet</b> H1 = H2 <sup>1)</sup> = 10.02  <b>Prise de rayures</b> G1 <sup>1)</sup> * = 9.65 G <sup>1)</sup> = 5.00 $\alpha$ 1 = 120° h* = 0.11 s = i <sup>1)</sup> * = 0°52'50" w =  <b>Canon</b> F <sup>1)</sup> * = 9.50 Z = 9.50  <b>Rayures</b> b = N = u = Q = 70.88 mm <sup>2</sup>
	<b>Autres indications</b> Fe <sup>1)6)</sup> = 0.15 delta L =		
Échelle 1.4:1  Dimensions en << mm >> Dimensions et tolérances pour les canons d'épreuve: Voyez Annexe CR 1.		Notes: 1) A' contrôler pour la sécurité 6) Feuille sur la bouche * Dimensions de base	

Reproduction interdite, même partielle, sans l'autorisation de la C.I.P.

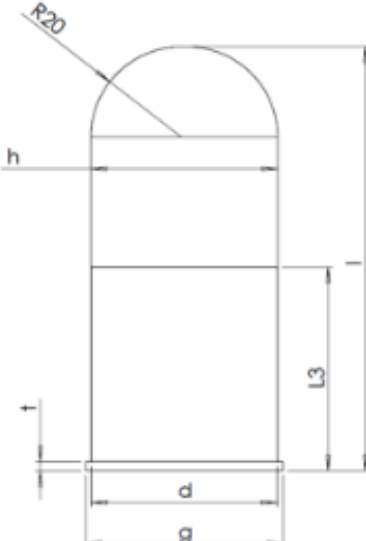
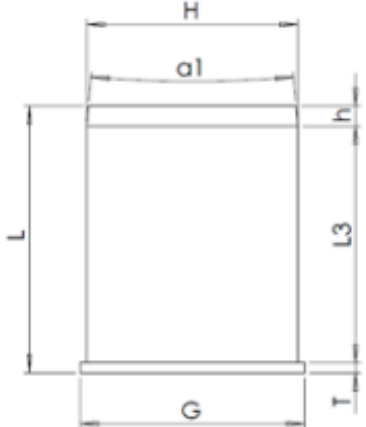
<b>40 x 46 BDLR X</b> Pays d'origine : FR		TAB	X																																																																												
		Date	12-05-30																																																																												
		Révision	20-11-10																																																																												
	<b>CARTOUCHE MAXIMALE</b>																																																																														
<table border="0"> <thead> <tr> <th></th> <th style="text-align: center;">Maxi</th> <th style="text-align: center;">Mini</th> <th></th> </tr> </thead> <tbody> <tr> <td><b>Culot</b></td> <td>dia. d = 41.20</td> <td>40.90</td> <td>(1)</td> </tr> <tr> <td><b>Bourrelet</b></td> <td>dia. g = 43.90</td> <td>43.60</td> <td></td> </tr> <tr> <td><b>Bourrelet</b></td> <td>ép. t = 2.03</td> <td>1.91</td> <td>(1)</td> </tr> <tr> <td><b>Sabot</b></td> <td>dia. h = 41.35</td> <td>41.20</td> <td></td> </tr> <tr> <td colspan="4"><b>Longueur :</b></td> </tr> <tr> <td><b>L3</b></td> <td>= 45.2</td> <td></td> <td></td> </tr> <tr> <td><b>l</b></td> <td>= 96.0</td> <td></td> <td>Tolérance : -2.0</td> </tr> </tbody> </table>				Maxi	Mini		<b>Culot</b>	dia. d = 41.20	40.90	(1)	<b>Bourrelet</b>	dia. g = 43.90	43.60		<b>Bourrelet</b>	ép. t = 2.03	1.91	(1)	<b>Sabot</b>	dia. h = 41.35	41.20		<b>Longueur :</b>				<b>L3</b>	= 45.2			<b>l</b>	= 96.0		Tolérance : -2.0																																													
	Maxi	Mini																																																																													
<b>Culot</b>	dia. d = 41.20	40.90	(1)																																																																												
<b>Bourrelet</b>	dia. g = 43.90	43.60																																																																													
<b>Bourrelet</b>	ép. t = 2.03	1.91	(1)																																																																												
<b>Sabot</b>	dia. h = 41.35	41.20																																																																													
<b>Longueur :</b>																																																																															
<b>L3</b>	= 45.2																																																																														
<b>l</b>	= 96.0		Tolérance : -2.0																																																																												
	<b>CHAMBRE MINIMALE</b>																																																																														
<table border="0"> <tbody> <tr> <td><b>Drageoir</b></td> <td>dia. G mini = 44.05</td> <td>+0.10</td> <td></td> </tr> <tr> <td><b>Drageoir</b></td> <td>pro. T mini = 2.00</td> <td>+0.10</td> <td>(1)</td> </tr> <tr> <td><b>Chambre</b></td> <td>dia. H mini = 41.50</td> <td>+0.20</td> <td>(1)</td> </tr> <tr> <td><b>Canon</b></td> <td>dia. B mini = 40.80</td> <td>+0.04</td> <td>(1)</td> </tr> <tr> <td><b>Canon</b></td> <td>angle a1 mini = 10°</td> <td></td> <td></td> </tr> <tr> <td><b>Canon</b></td> <td>N = 6 rayures</td> <td></td> <td></td> </tr> <tr> <td><b>Canon</b></td> <td>F = 40.8</td> <td></td> <td></td> </tr> <tr> <td><b>Canon</b></td> <td>Z = 41.4</td> <td></td> <td></td> </tr> <tr> <td><b>Canon</b></td> <td>B = 3.0</td> <td></td> <td></td> </tr> <tr> <td><b>Canon</b></td> <td>u = 1200 mm / tour</td> <td></td> <td></td> </tr> <tr> <td colspan="4"><b>Longueur :</b></td> </tr> <tr> <td><b>L3</b></td> <td>= 46.5</td> <td></td> <td></td> </tr> <tr> <td><b>h</b></td> <td>= 4.0</td> <td></td> <td></td> </tr> <tr> <td><b>L</b></td> <td>= 50.5</td> <td></td> <td>Tolérance : + 0.5 (1)</td> </tr> <tr> <td><b>L = L3 + h</b></td> <td></td> <td></td> <td></td> </tr> <tr> <td><b>E max</b></td> <td>= 200 Joules</td> <td></td> <td></td> </tr> <tr> <td><b>EE</b></td> <td>= 220 Joules</td> <td></td> <td></td> </tr> <tr> <td><b>Feuillure</b></td> <td>= 0.10 (canon manomètre)</td> <td></td> <td></td> </tr> <tr> <td></td> <td>= 0.50 (basculant)</td> <td></td> <td></td> </tr> </tbody> </table>				<b>Drageoir</b>	dia. G mini = 44.05	+0.10		<b>Drageoir</b>	pro. T mini = 2.00	+0.10	(1)	<b>Chambre</b>	dia. H mini = 41.50	+0.20	(1)	<b>Canon</b>	dia. B mini = 40.80	+0.04	(1)	<b>Canon</b>	angle a1 mini = 10°			<b>Canon</b>	N = 6 rayures			<b>Canon</b>	F = 40.8			<b>Canon</b>	Z = 41.4			<b>Canon</b>	B = 3.0			<b>Canon</b>	u = 1200 mm / tour			<b>Longueur :</b>				<b>L3</b>	= 46.5			<b>h</b>	= 4.0			<b>L</b>	= 50.5		Tolérance : + 0.5 (1)	<b>L = L3 + h</b>				<b>E max</b>	= 200 Joules			<b>EE</b>	= 220 Joules			<b>Feuillure</b>	= 0.10 (canon manomètre)				= 0.50 (basculant)		
<b>Drageoir</b>	dia. G mini = 44.05	+0.10																																																																													
<b>Drageoir</b>	pro. T mini = 2.00	+0.10	(1)																																																																												
<b>Chambre</b>	dia. H mini = 41.50	+0.20	(1)																																																																												
<b>Canon</b>	dia. B mini = 40.80	+0.04	(1)																																																																												
<b>Canon</b>	angle a1 mini = 10°																																																																														
<b>Canon</b>	N = 6 rayures																																																																														
<b>Canon</b>	F = 40.8																																																																														
<b>Canon</b>	Z = 41.4																																																																														
<b>Canon</b>	B = 3.0																																																																														
<b>Canon</b>	u = 1200 mm / tour																																																																														
<b>Longueur :</b>																																																																															
<b>L3</b>	= 46.5																																																																														
<b>h</b>	= 4.0																																																																														
<b>L</b>	= 50.5		Tolérance : + 0.5 (1)																																																																												
<b>L = L3 + h</b>																																																																															
<b>E max</b>	= 200 Joules																																																																														
<b>EE</b>	= 220 Joules																																																																														
<b>Feuillure</b>	= 0.10 (canon manomètre)																																																																														
	= 0.50 (basculant)																																																																														
Dimensions en "mm" Dimensions et tolérance pour les canons d'épreuve :		Notes : (1) A contrôler pour la sécurité																																																																													